

# Design Drafting NEWS

## Ron McDonald ADDA President

### A Retirees Musings

After spending several hours trying to find an appropriate topic for this message, I experienced several of my 'pet peeves' this week. So allow a retiree to pass on some of those to all of you. They are not listed in any particular order as to being major or minor.



Please note as follows:

**Cell Phones:** What an 'anchor' we now have. We can no longer work, travel, visit family or enjoy quiet time during a meal, when we do not have these devices at the ready, for the latest update. Land lines and the pay telephone are now extinct. Now I admit that they are useful tools but the tool now commands too much of our time.

**Texting:** This is the communication method now preferred by all. Example is my children, even my wife, as they will respond to any text message but will not answer the phone. I want to hear their voice and the message from me is important, at least I think so. What do I get? The voicemail saying 'so and so is not available. Please leave a message'. The message I leave is usually 'Answer the darn phone'.

**Sagging trousers/jeans:** It is a mystery to me as to why someone wants everyone to know what color/type of underwear they are wearing. Trying to be a 'gangsta' or just peer -pressure, who knows but it is definitely not a fashion statement. Just buy some Bermuda shorts in the color or plaid style of choice and wear them.

**Twitter:** See Texting.

**Facebook:** Now I admit that I use Facebook but mostly to keep track of children and recent stupid political stunts by both political parties. Also see Texting.

Continued on page 2....

## On the Drawing Board

*New Website Development moving ahead  
2014 Conference Set again for Kansas City Missouri  
Seeking Grant for New Discipline Certification  
Working on Partnerships with Major Corporations  
Mechanical Designer Examination Projected for 2015  
New and Revised Civil Examinations Projected for 2015*

## As Built

ADDA President	Page 1,2
Anniversary	Page 2
How Straight Must It Be?	Page 3,6
Certifications	Page 4-6
Bauer Ethics	Page 6
Computer Aided Drafting	Page 7
Platform Construction System	Page 8-12

## GET INVOLVED with ADDA

Your Membership or Certification  
should be more than a CARD

**Start a Professional Council  
Be a Contest Judge  
Promote Design Drafting Week  
Work with a local Chapter  
Join a Committee**

Continued from page 1....

**Emergency weather reports:** I know there is a need for these but it has become an issue overplayed by local stations for ratings. Here in Oklahoma, if one dark cloud appears or there are a few rain drops, the local stations go into emergency mode, advising that there may be slick streets or worse. This also immunizes the population to actual warnings when they are needed, as there is a tendency to ignore oft repeated alarms.

**Daylight Savings Time:** My Grandfather who was a farmer hated it and like him so do I. Arizona and some parts of Indiana do it right.

**Email:** In the office, this took the place of the interoffice memo and most recently the facsimile machine. Useful but overused as a means of communication. In the office we now email one another instead of getting up and walking to the next cubicle to communicate. Whatever happened to person to person communication? Also the reason for hated 'spam email'.

**I need this today:** Often the reason someone in management needs something today is they did not perform their function in properly relaying information when requested. Granted there are emergencies but this is mostly bogus and a sign of poor communication by management.

**ASAP:** See 'I need this today'.

**Poor project management:** There are schedules to meet or the dollars do not roll in but too often, agreed to schedules are based on the tools and manpower available. Upper management then cuts the time available for project completion by half, not adding any additional tools or manpower. I'm still looking for the 'miracle' key on the keyboard.

**Being tardy:** With all of the equipment we have now available, from watches to cell phones, there is no excuse for anyone being late, barring an accident, illness or incidents totally out of their control. Being tardy for anything is a time waster for others involved, particularly meetings. And finally,

**Not asking questions:** This really frustrates me as the old adage states 'There is no such thing as a dumb question'. As a manager, it is frustrating to ask if there are any questions concerning an assignment and there are no replies. Everyone is stone silent but afterwards the emails and text start flowing concerning the assignment. Again this does not add value of any kind. If the assignment is not clear, ask your questions as to why it is not. Spending extra time initially making clear as to what is expected is a timesaver.

Thanks for letting me share some of my 'pet peeves'. I hope everyone had a great summer and are looking forward to the fall season. Now for the commercial: ADDA is the only organization that promotes and supports the design/drafting profession for professionals and students alike. All of the ADDA Board members are volunteers and are always looking for ways to enhance ADDA's presence in the design/drafting community. Contact us if you have any issues or suggestions.

## *Happy 10 Year Anniversary Donna!*

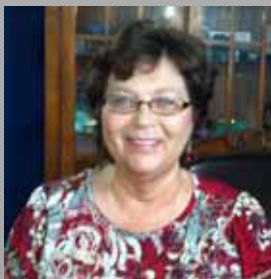

For the past 10 years Donna Brenton has worked for ADDA as the Administrative Manager and has helped ADDA become the professional and profitable organization that it is today. Prior to ADDA, Donna had 15 years in Customer Service and Data Management. Donna is married, has five children, and six grandchildren.

## How Straight Must It Be?

Dennis Schwartz

Straightness applied to a cylindrical feature (part 1).

Figure 1 shows an example of straightness applied to a cylindrical feature. The feature control frame is attached to a leader directed to the surface. All circular elements of the surface are to be within the specified size tolerance (10.00/9.85). Each longitudinal element of the surface must lie between two parallel lines separated by the straightness tolerance (0.05). In this case, the straightness tolerance must be less than the size tolerance. As the diameter of the cylinder approaches its maximum material condition(MMC), the actual amount of straightness allowed will decrease because the size limit must not be violated. The form must be perfect if the cylinder is at MMC (see table 1).

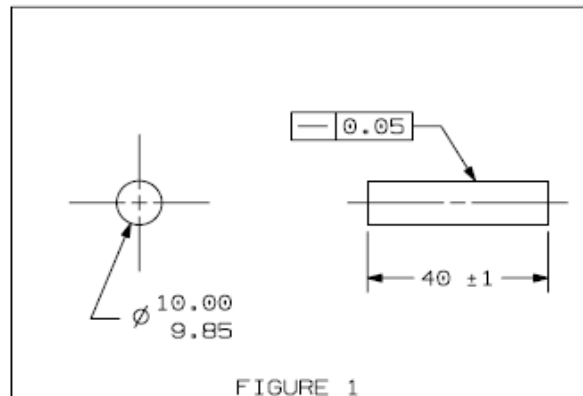
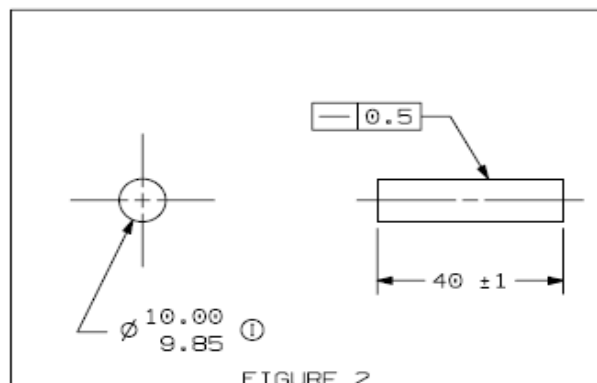

Table 1

Diameter of cylinder	Straightness Tolerance
9.85	0.05
9.9	0.05
9.95	0.05
9.97	0.03
9.98	0.02
9.99	0.01
10	0

Figure 2 shows the same cylindrical feature. In this example, the independency symbol has been applied to the size dimension. The independency symbol removes the requirement of perfect form at MMC and the straightness tolerance may be larger than the size tolerance. In this case the straightness tolerance is 0.5. All circular elements must be within the specified size tolerance (10.00/9.85). Each longitudinal element of the surface must lie between two parallel lines separated by the straightness tolerance (0.5). See Table 2



Cont'd on pg. 6



*Congratulation's  
 To The Following  
 For Passing the Certification Exam (May thru September 2013)*

**Mechanical AD (cont'd.)**

- |                                      |  |
|--------------------------------------|--|
| Ryan Maze-Bay City MI                | John Castle-Homosassa FL               |
| Darby McCracken-Freeland MI          | Michael Cummins-Crystal River FL       |
| Nathan Cordeiro-Haverhill MA         | Julia Gruber-Dunnellon FL              |
| Keith Gregg-Cleveland TN             | Nicholas Franco-Inverness FL           |
| Amanda Lasher-Riceville TN           | Cayle Hudgens-Crystal River FL         |
| Karen Martinez-Cleveland TN          | Daniel Reese-Dunnellon FL              |
| Zachary Bowers-Pomaia SC             | Quinton Roberts-Crystal River FL       |
| Christopher Rafferty-Culloden WV     | Jamie Wiggert-Christiansburg FL        |
| Aaron Holiday-Freeland MI            | Jonathan Colucci-Sitrus Springs FL     |
| Robert Coartney-Parkersburg WV       | Shawn James, Jr.-Crystal River FL      |
| Samuel Sinicki-Bay City MI           | Nolan Deibler-Christiansburg VA        |
| Zachariah Winiecke-Bay City MI       | Sarah Peters-Christiansburg VA         |
| William Bleser-Plantation FL         | Emory Yearwood-Christiansburg VA       |
| Derek Starkweather-Floral City       | Dylan Discher-Crystal River FL         |
| John Hess-Dunnellon FL               | Ricardo Tafoya-Crystal River FL        |
| Matthew Barnes-Warrenton VA          | Levi Lee-Lauderhill FL                 |
| Dennis Johnson, Jr.-Coconut Creek FL | Aaron Strait-Inverness FL              |
| Trevor Compton-Christiansburg VA     | Derrick Schenck-Inverness FL           |
| Mayelyn Parker-Pompano Beach FL      | Dakota Brown-Dunnellon FL              |
| Nathaniel Meeks-Lecanto FL           | Ryan Johnson-Homosassa FL              |
| Demarco Dalton-Haverhill MA          | Ethan Walters-Christiansburg FL        |
| Abigail Monson-Haverhill MA          | Melissa Huang-Sunrise FL               |
| Eduardo Aguirre, Jr.-Sunrise FL      | Rachel Rahmes-Christiansburg VA        |
| Deonna Anderson-Mt. Vernon MO        | Hayden Ridge Wilburn-Christiansburg VA |
| Joshua Luckham-Inverness FL          | Justin Bowler-Christiansburg VA        |
| Austin Camp-Citrus Springs FL        | Corey Caldwell-Christiansburg VA       |
| Eric Bass-Christiansburg VA          | David Myrick-Inverness FL              |
| George Harty-Inverness FL            | Jordan Brown-Homosassa FL              |
| Kyle Dove-Citrus Springs FL          |  |

**Welcome**

ADDA would like to welcome a  
 New Student Chapter:

ITT Technical Institute  
 San Antonio  
 East Campus  
 San Antonio, TX



***“Strive for perfection in  
 everything you do.  
 Take the best that exist  
 and make it better.  
 When it does not exist,  
 design it”***

***Sir Henry Royce***

**(Continued from pg. 3-Schwartz)**

Table 2

Diameter of cylinder	Straightness Tolerance
9.85	0.5
9.9	0.5
9.95	0.5
9.97	0.5
9.98	0.5
9.99	0.5
10	0.5

Note: All dimensions are in millimeters  
 Be sure to see the next newsletter for a continuation of straightness applied to a cylindrical feature.



## Reducing Retaliation For Whistleblowing

The Ethics Resource Center's 2011 National Business Ethics Survey found that a staggering one-in-five employees (22%) who reported ethics problems also reported experiencing some form of retaliation because of it. Those are obviously wildly unacceptable figures. Though preventing retaliation will never be a foolproof operation, it is amazing how few organizations follow even common sense measures to prevent it.

Here are a few of the essentials:

- Have clear, easily-followed policies and procedures both for reporting ethical and legal concerns as well as for dealing with any retaliation for the making of such reports. If you don't have these policies and procedures - and you haven't trained *every* individual in your organization on them - you're not even in the game.
- The above training needs to include not only how and when to report ethical concerns but also needs to explicitly outline the steps to be taken if reporters perceive even the smallest taste of retaliation.
- The above training needs to also make clear the actions that will be taken against any individual found to have retaliated for reporting ethical or legal concerns.
- Make sure that everyone in the organization knows that everyone else is also getting exactly the same message and treatment from the front lines up through senior management. If there is any inequity in how retaliation is handled - or even if there is the perception that it is so - your efforts will be significantly compromised. It simply does no good to tell an employee they will be protected if they don't feel that their supervisor or manager has heard the same message and will be held to it. After all, in most organizations, fear of retaliation from supervisors and managers is far more prevalent than is the fear of peer-to-peer retaliation.
- Perhaps the toughest part of all of this is absolutely the most essential. That is that you have to actually mean all of the above. Once any portion of your policies or actions are perceived as insincere or inadequately fulfilled, your power to significantly reduce retaliation has been compromised terribly.

When reports of ethics concerns aren't anonymous, be sure to follow-up with the reporter at least twice. Not only is this an opportunity to question them to assure that no retaliation has occurred but it provides two more opportunities to thank them for their willingness to speak up when they saw matters of concern. Such speaking up can never be reinforced too much!

*Christopher Bauer helps companies create and implement high-impact, high-ROI ethics and values training programs. In addition to consultation on program development and implementation, he also provides keynotes and seminars on how to prevent costly employee ethical and legal problems. Information on his most frequently requested keynotes and seminars can be found by clicking [here](#).*

*Interested in ethics commentary and resources? Christopher Bauer's ETwitter feed is [@ethicstweet](#).*

*"Better Ethics NOW: How To Avoid The Ethics Disaster You Never Saw Coming (Second Edition)" is available for purchase [here](#). "Every manager and executive can learn from reading Better Ethics NOW." - Steve Odland - CEO - Office Depot*  
copyright 2013 by Christopher Bauer - all rights reserved  
(Information on Bauer Ethics Seminars is available at [www.bauerethicsseminars.com](http://www.bauerethicsseminars.com).)

## Congratulation's

To The Following

For Passing the Certification Exam (May thru September 2013)

### Architectural AD

Frank Brudi, Jr.-Cape Coral FL  
Joseph Hobba-Buffalo WV  
Andrew Tutko, II-Houtzdale PA  
Emmanuel Lopez-Cape Coral FL  
Alycia Cooke-West Palm Beach FL  
David Decembre-Riviera Beach FL  
Leonardo Martinez-West Palm Beach FL  
Kerry Ulysse-Lake Worth FL  
Reginald Walker, Jr.-West Palm Beach FL  
Brandon Burwell-Union NJ  
Benjamin Chung-Union NJ  
Jason Pelletier-Clermont FL  
Marcus Davy-Boynton Beach FL  
Lens Desire-West Palm Beach FL  
Gabryelle Estrada-West Palm Beach FL  
Richard Petruccelli-Union NJ  
Peterson Philippe-West Palm Beach FL

### Architectural CD

John Keen-Franklin TN  
Jonathan (Frank) Buck-Aberdeen SD  
Brian Voss-Hartford SD  
James White-Haleyville AL  
Dennis Bohmont-Mitchell SD  
James Hartwell-Belle Fourche SD  
Jason Boeding-Caputa SD  
Shane McDevitt-New Castle PA  
Mary Smith-Brown-Athens TN  
Michael Satter-Sioux Falls SD  
Mark Pier-Crofton NE  
Thomas Rogers-Ft. Pierre SD  
Gary Siska-Sioux Falls SD  
James Schmit-McCook Lake SD  
Mike Sees-Irene SD  
Jonathan Bunch-Hephzibah GA  
Ty Barker-Armour SD  
John Birdsall-Martin SD  
Paul Kruse-Lennox SD  
Jeff Schlepp-Sioux Falls SD  
Richard Cernich-Inverness FL

## Computer Aided Drafting – the beginning

Gene R. Fosheim, CD

In June of 1974 I graduated from college with a degree in Industrial Design, but with no plans for employment. Since I lived in Everett, Washington, just ten minutes from the huge Boeing plant, I decided to drop by and fill out a job application. Coming out of college, I didn't know anything about the working world; I just knew I wanted to be a drafter or designer. Boeing personnel looked at my application and hired me on the spot as a tool designer.

I quickly caught on to the tool design field and loved my job. Drafting and design was quite satisfying plus I was making a great salary for a young guy. After a couple of busy and exciting years, the aircraft industry slowed down and I was one of the few young employees left. In 1976 the Everett 747 tool design group got its first CAD stations and I was picked as one of the first designers to be trained on the strange new systems. Our initial group filled a small windowless room with four Gerber IDS stations and a huge flatbed plotter. These stations cost a fortune



and we knew that we had the best technology in the world at the time.

The Gerber IDS system was the latest in CAD technology but primitive by today's standards. Each station had a big square metal 20" monitor with a green image and a keyboard used for typing distances and notes. Below the keyboard was a horizontal sliding joystick with a press button to input data. One of the best ways to draw a simple object was to set up a .10 grid and just snap lines to it. In a room full of Gerber systems one would hear constant clicking. All of our drawings were created

in 2D and printed out in black ink on Mylar on our slow and deliberate but fascinating to watch 4' by 6' plotter. If we needed a larger plot, there was a 7' by 21' flatbed plotter available in another department. Our lead designer was a chain smoker and the little CAD room was constantly filled with a green haze.

Our Tooling group discovered many challenges presented by CAD in the first few years. I had the privilege of creating the first CAD drawing released in tool design at the Boeing Company. Most of the old-timers were extremely skeptical of the merits of CAD. Once plotted out and released, CAD drawings were treated no different than manual drawings. They were changed and updated manually and datasets were not managed. Tooling drawings at the time were all drawn with plastic lead on Mylar so I first had to convince management that ink on Mylar could be erased. Once datasets were retained and CAD drawings began to be updated by computer, there was the dilemma of putting the supervisor's signature on the drawing by hand.

The early years of CAD were hampered by computer geeks promising way too much, programs being delayed by the slow CAD systems, and no one knowing the best uses for CAD. It probably took us three years on the new 767 program to show that CAD was indeed the future of drafting and design. By the time the 777 program came along, almost everything was designed in 3D, including the aircraft mock-up. Those were exciting years and I'm glad I had a chance to experience them.

Platform Construction System  
 Field Trip & Wood Models  
 A Case Study

Ibrahim Y. Vaid  
 Effat University (KSA)  
 ibrahimyvoid@hotmail.com

Platform Construction System

Wood light Frame (WLF) is the dominant system of contemporary construction. It was invented in the US about 200 years ago, and it is a uniquely North-American construction system. It is used in residential and light commercial buildings in the US, Canada, Australia, and many other parts of the world. Initially, it was used in a form of balloon framing, but it improved over time to platform. In platform construction, the floor is built and then walls are erected on top of it. When a building is more than 1 story, the 2<sup>nd</sup> floor platform is erected on a top of the 1<sup>st</sup> story walls. Platform construction is easy to erect because it creates a platform space for workers to stand and to work.

Case Study

Every semester, in lecture courses, students are required to work on a project which is worth 15% of the final grade. Also in lecture courses students have an opportunity to go on a field trip related to the project or a guest speaker is invited to share real world experience. The project theme and field trip location is discussed and decided in the 2<sup>nd</sup> week of the semester. In spring 2013, students and the author of ARCH 352, Building Structural and Material course decided to work on a project related to "wood". The decision was made after reviewing the tentative schedule of chapters which would be covered in 15 weeks. For a field trip, it was decided to visit a **wood door factory-Arabian Woodwork (AWW)** located in Jeddah, the Kingdom of Saudi Arabia (KSA). Students were required to take notes during the field trip and write a report indicating what they have learned from the trip and how they would apply it in their design projects. For the project, the students and the author decided to create a **wood model of platform-frame construction** of 1 story residential house with basement. Students were divided into 5 groups. Each group received a set of construction drawings from author. Students worked on a model for 8 weeks and they were asked to meet the author every week in order to improve accuracy of different parts of model. Additionally, the author drew roof trusses on AutoCAD for each group. See photo 1. Similar to a field report, students were required to keep track of model developments and write a report indicating what they have learned from the model in term of different parts of platform construction and how structure is being built.

Results

The field trip and model results were prodigious. Students learned the processes used to make solid wood doors and fire rated solid doors; see photos 2-4 of the field trip. The students' models were better than the expectations of the author; see photos 5-8. One of the biggest achievements was showing the different parts of platform construction. By making models students had a better understanding of the correct locations of each part and sequence of construction. They learned about footing, foundation wall, pad footing, rebar, keyway, drain tile, pea gravel, column, expansion joint, concrete floor, anchor bolt, sill sealer, sill plate, beam pocket, beam, floor joist, solid header, bridging, floor deck, sole plate, stud, roof truss, roof deck, plywood, oriented strand board, sheathing, insulation, and much more.

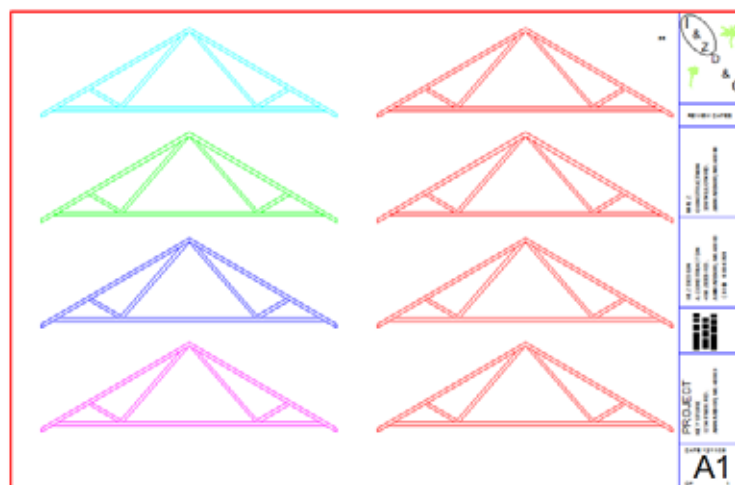

Photo 1: Trusses were drawn on AutoCAD, as a template for roof trusses.



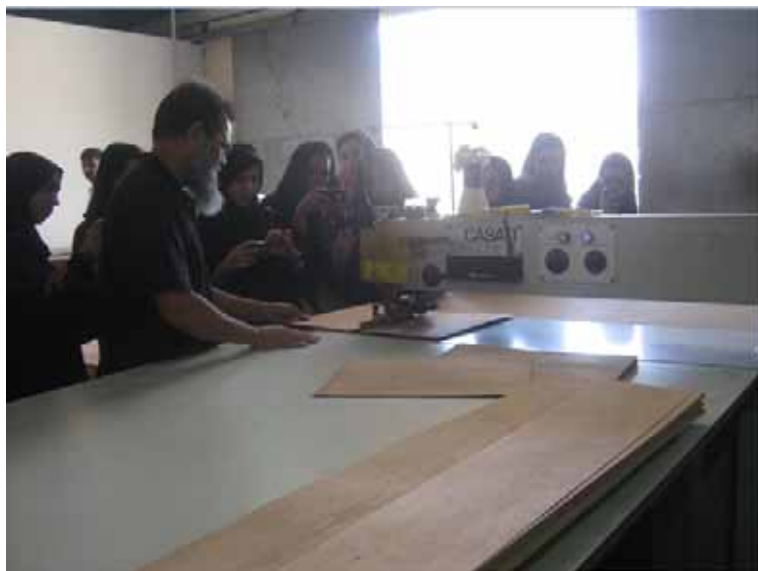

Photo 2: Students are watching how Door Veneer Sewing Machine works. Photo by Vaid



Photo 3: Door panel is coming out of Panel Press Machine. Photo by Vaid



Photo 4: Students are taking notes. Photo by Vaid

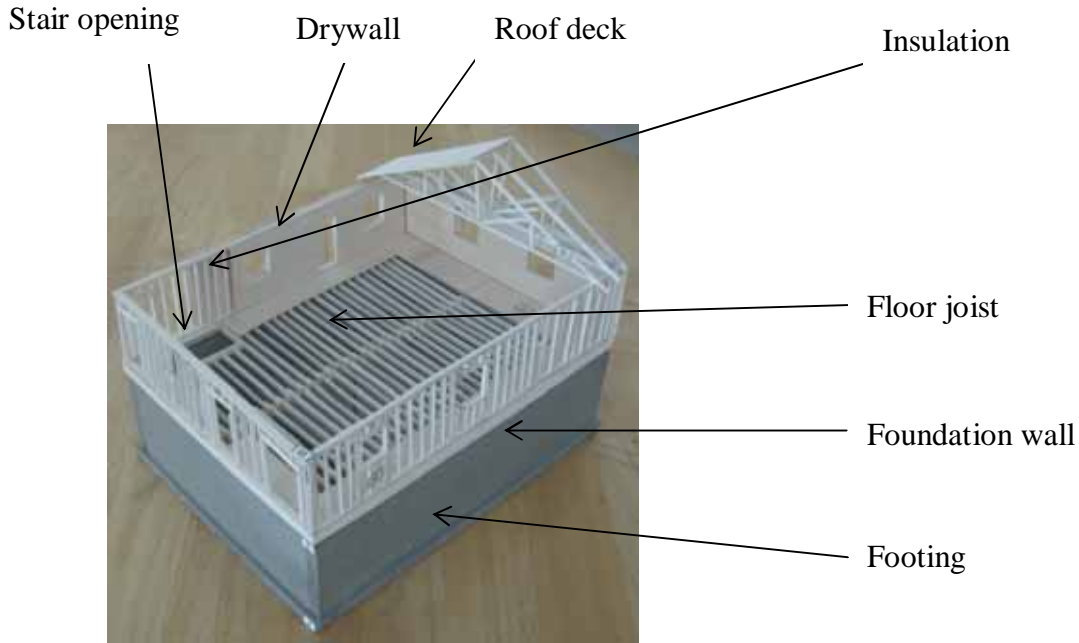
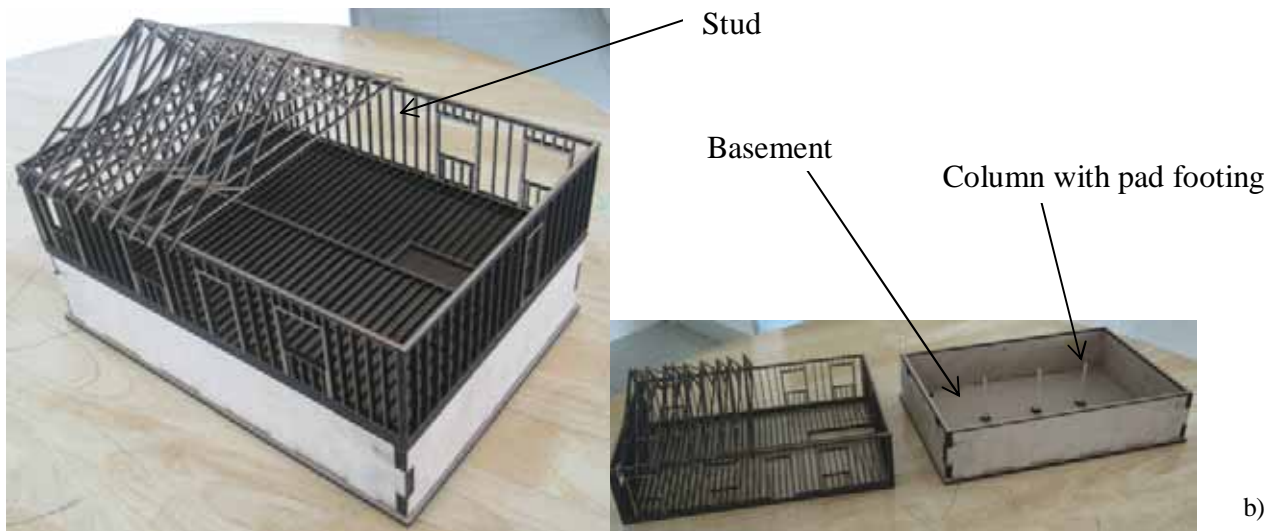

Photo 5: Wood Light Frame (WLF) Platform Construction Model. Photo by Vaid



a)

b)

Photo 6: Wood Light Frame (WLF) Platform Construction Model (a). Basement and 1<sup>st</sup> floor is not connected to clarity (b). Photo by Vaid

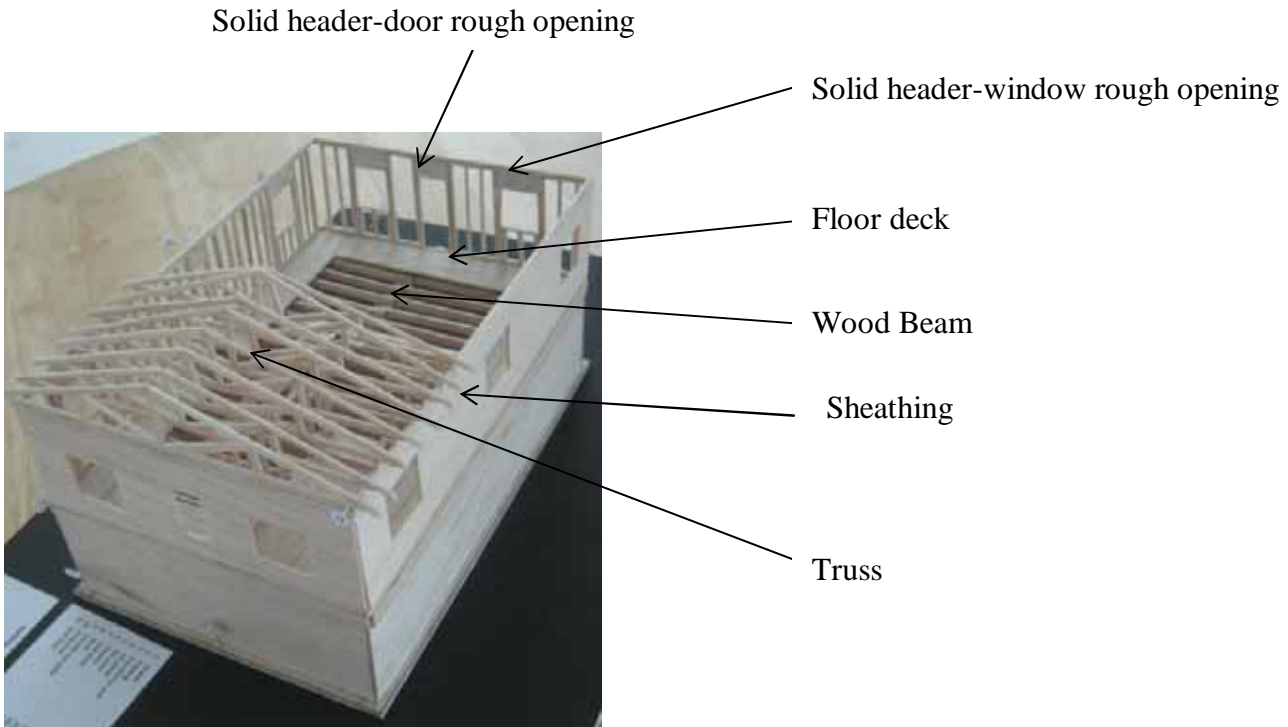

Photo 7: Wood Light Frame (WLF) Platform Construction Model.  
 Photo by Vaid



Photo 8: Rough opening of windows and elements. Photo Courtesy of Eman Al-Somali

Finally, the following are quotes from randomly picked students Model and field trip comments. Names of students have been replaced to student numbers for privacy reasons.

**Students Comments-Platform Construction System**

**Student 1:** After I learned the platform construction theoretically, making the model gave me the chance to learn it practically. I have learned from making wood platform model is how to place each elements of the platform correctly. I started to sense the spaces and the dimensions as well as the proportions of the wood construction. Also, I learned that the foundation is the strongest part which carries the entire building load in addition to the wood. Having accurate measurements will make a process going easier and faster. Finally I became familiar with the steps and the stages to build a wood platform house.

**Student 2:** After making a model, I benefited of exploring my knowledge and understanding on how to construct a WLF house. Also I enhanced my vocabulary and now have a better understanding of different elements and its locations. Nonetheless without the encouragement, help and valuable information of my course instructor wouldn't make me able to reach this achievement.

**Student 3:** Building this model by myself allowed me to rationalize the chosen assembly, knowing how to construct a wood light frame step by step and understood why and how each element is placed.

#### Students Comments-Field Trip Arabian Woodwork-wood door factory

**Student 1:** It was an interesting trip with a lot of useful information. We learned a lot about wood and furniture manufacturing; at the end we took a group picture with the company sign and then head pack to the university after a long day.

**Student 2:** Arabian wood company is one of the only two local companies in Saudi Arabia that manufactured fire rated doors. The factory extended from manufacturing doors only to produce also furniture. New information's were gained from this trip about manufacturing doors. Mr. Khan was very informative, welcoming and happily answered our several questions.

**Student 3:** I can say that our visit to the factory was very fruitful. It was great to see, smell and touch wood in all its different forms. I have always believed that the educational process should extend beyond the traditional spoon-feeding techniques and that students should engage in various activities to enrich their educational experience.

During my visit to the factory I have learned several things. First and most interestingly, we have been informed by Mr. Vaid that the design documents of the doors are drawn using AutoCAD, which means that I can do my internship in that factory and get more into details in the designing process of doors. Second, I learned about the wood prices, what makes one kind of wood more special than the other, which will definitely affect my future choice of material? And last but not least, I became more certain that it is better for me as a student to learn by doing, just as Benjamin Franklin said: "Tell me and I forget, teach me and I may remember, involve me and I learn".

**Student 4:** Wood is a very important material. There is a huge need of companies such Arabian wood work. We must be an in depended country manufacture wood by itself without the need to any other countries. In addition, the trip to Arabian Wood Work is one of the best trips because I took a lot of information that I need to know. It will be helpful if other architecture students could go to Arabian Wood Work (AWW) with us.

**Student 5:** This trip was really beneficial for us, as we were exposed to the real life and to the real materials. We learned a lot as well as we understood exactly each and every single work they did. The workers and so does Mr. Waseem Ahmed Khan-Operating Manager was helpful by explaining each part of the Arabian Wood Work (AWW).

#### Acknowledgements

The author thanks all of the students for sharing their field trip and model experiences. Special thanks go out to the management of AWW, especially, Mr. Khan who made the field trip possible by obtaining special permission from AWW headquarters to allow female students attend. Further, the author thanks the anonymous reviewers for their detailed and helpful comments.

#### About the author

Ibrahim Vaid is an educator, vocational educational consultant, and has a design practice. He is currently teaching as a visiting professor in the KSA and can be reached at [ibrahimyaid@hotmail.com](mailto:ibrahimyaid@hotmail.com) and 810-610-6769.

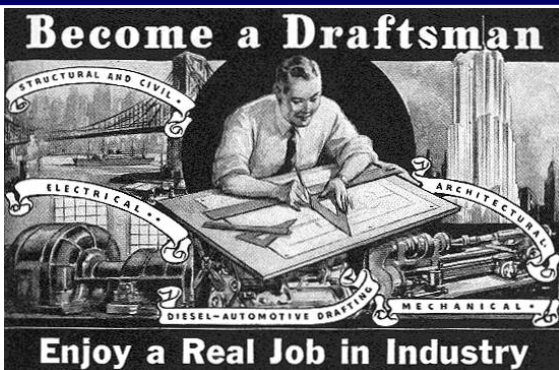

**ADDA supports SkillsUSA Annually**

**Provides the National SkillsUSA Drafting Examination**  
**Provides the National Drafting Contest Judges**  
**Award ADDA Membership to the SkillsUSA Winners**  
**ADDA Directors are Contest Program Chairs for the**  
**Architectural & Mechanical Competitions**  
**Assist in many State Competitions**



Changing the Way Companies  
**Develop Products**

1-888-225-7579 • www.eacpds.com • Twitter @eacpds • YouTube.com/eacpds  
 Training • Engineering & Design • Assessments • Software • Implementation

PTC® University • Learn  
**creo™** • Design  
**Mathcad®** • Capture  
**Windchill®** • Collaborate



**Chief Architect®**  
 3D Architectural Design Software



- Architectural Drafting
- Building & Construction
- Family & Consumer Science
- Interior Design & Housing

- Graphics & Theater Arts
- Ag & Horticulture
- Criminal Justice
- Applied Math
- Cabinetry



- Curriculum Provided
- 400+ Training Videos
- Step-by-Step Tutorials
- Certification Exams
- User-Friendly 3D Design for Students

No CAD Experience Needed!

- 2D & 3D Design
- Artistic & Photo Realistic Rendering
- Landscaping & Decks
- Kitchens & Baths
- Residential & Light Commercial
- CAD & Construction Drawings
- Materials List & Cost Estimating

[www.chiefarchitect.com](http://www.chiefarchitect.com)

1-800-482-4433



**ADDA supports SkillsUSA Annually**

**Provides the National SkillsUSA Drafting Examination**  
**Provides the National Drafting Contest Judges**  
**Award ADDA Membership to the SkillsUSA Winners**  
**ADDA Directors are Contest Program Chairs for the**  
**Architectural & Mechanical Competitions**  
**Assist in many State Competitions**



EVERYTHING in OFFICE SUPPLIES  
 FREE SHIPPING  
[www.addabizsupplies.com](http://www.addabizsupplies.com)



## Graduate Lapel Pins

ADD<sup>A</sup> has authorized the creation of a new product for Certified Curriculum Program Graduates. These pins are 1" in diameter, with Turquoise and

Black Cloisonné filled with a bottom rocker indicating a Certified Program Graduate. These pins are available for \$5.00 each, or \$3.50 each if you order 2 or more. Price includes all shipping and handling. Pin orders must be made by the instructor and are shipped directly to the instructor of the program. No sales will be made to individuals.

## Graduate Certificates

As a reminder, Graduates from ADD<sup>A</sup> Certified Programs are entitled to Graduate Certificates indicating their completion from an ADD<sup>A</sup> Approved Program. These Certificates are not Certified Drafter Certificates. This only indicates ADD<sup>A</sup> has approved the material content of the schools curriculum.

## ADD<sup>A</sup> Signature Products

Products Listed - Include cost of delivery  
 Please allow 2-3 weeks delivery time.  
 Express Delivery Available at additional cost.



Authentic Miniature Louisville Slugger Baseball Bat  
 ADD<sup>A</sup> Signature Cap Hidden Buckle Adjustable Strap  
**\$15.00 each**

ADD<sup>A</sup> Signature Shirts by Blue Generation  
 100% Cotton Twill - LS or SS - Men's and Women's  
 Over 20 Colors Available Men's Tall Available in Most Sizes  
 Visit: <http://www.bluegeneration.com/> search 8213 for colors / sizes



One Price - Any Size  
**\$33.00** Delivered



Teaching Systems, Inc.  
 (800) 762-4133  
[www.teachingsystems.com](http://www.teachingsystems.com)

For more information

TSI is a leading provider of software and hardware solutions for the design and drafting industry. We offer a wide range of products and services to meet the needs of our customers. For more information, please contact us at (800) 762-4133 or visit our website at [www.teachingsystems.com](http://www.teachingsystems.com).



## GET INVOLVED with ADD<sup>A</sup>

Your Membership or Certification should be more than a CARD  
 Start a Professional Council—Be a Contest Judge  
 Promote Design Drafting Week or Work with a local Chapter

the  
**CadCARD** SLIDE CHART

ADDA Member Discounts 10%

<b>US Version CadCARD</b>	<b>\$18.90</b>
<b>ISO Metric CadCARD</b>	<b>\$18.90</b>
<b>ANSI/Arch Metric CadCARD</b>	<b>\$18.90</b>
<b>Wallet-Size CadCARD JR</b>	<b>\$ 7.20</b>
<b>All Four – One of Each</b>	<b>\$56.70</b>



The full-featured CadCARD Slide Charts (U.S. or Metric Versions) are reference tools for use with AutoCAD. Designers, architects, engineers, and drafters find them to be quick, easy to use aids in many of the day-to-day CAD tasks that would otherwise have them reaching for a calculator. Instructors use CadCARDS to assist in explaining many CAD concepts such as scale and its effect on drawing elements. CadCARD JR features a reversible insert for calculating drawing scales, scale factors, inverse multipliers, and text heights for commonly used sheet sizes in both engineering *and* architectural units. CadCARDS become instant reference tools for everyone from the new user to the seasoned pro.

CadCARD Slide Charts are compatible with all versions of AutoCAD and other software that functions with AutoCAD. In addition, many features are useful with other CAD software such as IntelliCAD, Microstation, Solidworks, Revit, Solid Edge, BIM, Inventor, TurboCAD, and Mechanical Desktop.

**Free Shipping**      **Secure Ordering**

10% Discounts On-Line for ADDA Members

[www.cadcard.com/id40.html](http://www.cadcard.com/id40.html)

**Autograph Technical Services**

# International Museum of Design Drafting

Technical Illustration - Graphic Arts  
 Engineering and Architectural Design

ADDA authorized the creation of the International Museum of Design Drafting on April 16, 2010 in Louisville Kentucky with the purpose of collecting, displaying and preserving the history of the Design, Drafting, Architectural, Engineering and Graphics Professions for future generations.

**If you would like to donate monetarily, journals, tools, books or any items related to the profession it would be greatly appreciated. Currently about 400 items are on display in our lobby. ADDA is seeking more items with plans to build a facility to house the items in the future.**

**Help us Preserve our past for the future.**

*A Subsidiary of the American Design Drafting Association - a 501(c)3 Non-Profit Corporation and Charity for the education and preservation of the design profession and history.*

# PEARSON EDUCATION

## A.D.D.A's Top Picks For 2013



ISBN-10	Title	ISBN-10	Title
0135124646	<b>AutoCAD 2011 for Interior Design &amp; Space Planning</b>	013507925X	Statics and Strength of Materials for Architecture and Building Construction
0132150808	<b>Workplace Skills for Success with AutoCAD 2011: Basics</b>	0135090490	Technical Drawing with Engineering Graphics
0135122309	<b>AutoCAD 2011 in 3D: A Modern Perspective</b>	0135090490	Technical Drawing
0138016364	Introduction to AutoCAD 2011: A Modern Perspective	0135132150	<b>Architectural Drawing and Light Construction</b>
0135000688	<b>Civil Drafting Technology</b>	0136097081	<b>Mathematics for the Trades: A Guided Approach</b>
013713696X	<b>Design Graphics: Drawing Techniques for Design Professionals</b>	0135114004	<b>Mathematics for Carpentry and the Construction Trades</b>
0137033036	Codes, Regulations, and Standards in Interior Design	0135038782	<b>Blueprint Reading for the Machine Trades - Revised</b>
0135093570	Architecture and Interior Design: An Integrated History to the Present	0132376199	Residential Landscape Architecture: Design Process for the Private Residence



**ADDA SPECIAL...** Order now to receive **25% off** of list price and **FREE shipping!**

For additional information on these titles, please contact Dianne Fortier at: [dianne.fortier@pearson.com](mailto:dianne.fortier@pearson.com) . To make a purchase please visit her website at: [www.informit.com/sales/df](http://www.informit.com/sales/df) .



## LOWER MEMBERSHIP RATES

EFFECTIVE July 01, 2013

Code	Description	Fee
<b>INDIVIDUAL ANNUAL MEMBERSHIP in North America</b>		
PNC1	Professional in North America-First Year	\$ 89.00 annually
PCD1	Professional ADDA Certified in North America	\$ 84.00 annually
PM2	Professional-Second Year	\$ 75.00 annually
PM3	Professional- Third Year	\$ 70.00 annually
PM4	Professional- Forth Year	\$ 65.00 annually
PM5	Professional- Fifth Year	\$ 60.00 annually
PM6	Professional- Sixth-Tenth Year	\$ 55.00 annually
PM7	Professional- Eleventh Year	\$ 50.00 annually
PM8	Professional- 20 Years +	\$ 45.00 annually
<b>INDIVIDUAL MEMBERSHIP PACKAGES in North America</b>		
PMS1	Professional Select- <u>ADDA Certified</u> Special 3 year Select Membership Package	\$215.00 3 years
PMS2	Professional Select- <u>ADDA Certified</u> Second Renewal of 3 year Select Membership Package	\$170.00 3 years
PMS3	Professional Select- <u>ADDA Certified</u> Third Renewal of 3 year Select Membership	\$150.00 3 years
PMS4	Professional Select- <u>ADDA Certified</u> Forth Renewal of 3 year Select Membership	\$135.00 3 years
PME1	Professional Elite - <u>ADDA Certified</u> Special 5 year Elite Membership Package	\$325.00 5 years
PME2	Professional Elite - <u>ADDA Certified</u> Second Renewal of 5 year Select Membership	\$250.00 5 years
PME3	Professional Elite - <u>ADDA Certified</u> Third Renewal of 5 year Select Membership	\$225.00 5 years

### GROUP MEMBERSHIP PACKAGES in North America

PG11	Professional Group 1 Company Years 1-5 (requires 6-49 Members from same Facility) Years 6 forward	\$60.00 annually \$55.00 annually
PG12	Professional Group 1 Company Years 6-10 (requires 6-49 Members from same Facility) Years 11forward	\$55.00 annually \$45.00 annually
PG21	Professional Group 2 Company Years 1-5 (requires 50+ Members from same Facility)	\$55.00 annually
PG22	Professional Group 2 Company Years 6-10 (requires 50+ Members from same Facility)	\$50.00 annually
PG31	Professional Group 3 all Companies 11years +	\$45.00 annually

### EDUCATIONAL MEMBERSHIP in North America

PME1	Professional Educational First Year	\$ 75.00 annually
PME2	Professional Educational Second Year	\$ 75.00 annually
PME3	Professional Educational - Third Year	\$ 70.00 annually
PME4	Professional Educational - Forth Year	\$ 65.00 annually
PME5	Professional Educational - Fifth Year	\$ 60.00 annually
PME6	Professional Educational - Sixth-Tenth Year	\$ 55.00 annually
PME7	Professional Educational - Eleventh Year	\$ 50.00 annually
PME8	Professional Educational - 20 Years +	\$ 45.00 annually

### INSTITUTIONAL & SCHOOL MEMBERSHIP

ISM1	Institutional - <u>3 Memberships Included</u>	\$210.00 1st Year
ISM2	Institutional - <u>3 Memberships Included</u>	\$200.00 2nd Year
ISM3	Institutional - <u>3 Memberships Included</u>	\$190.00 3rd Year
ISM4	Institutional - <u>3 Memberships Included</u>	\$180.00 4th Year

### CORPORATE MEMBERSHIP PACKAGES in North America

PCM	Professional Corporate Membership	\$50.00 annually
-----	-----------------------------------	------------------

Rate Changes to \$45.00 after 10 years continuous membership.  
Contact ADDA for details. (based on Corporate Renewal) Corporate Membership is available by downloading the Corporate Membership Package Application at [adda.org](http://adda.org)

# Design Sustainably Build Efficiently

The Seasons of Design are Changing Rapidly  
Are you preparing for an Efficient Transition ?



Providing 4 Days of Education  
Professional Development  
Workshops & Certification

April 08-11, 2014 Kansas City Missouri visit [adda.org](http://adda.org)